

T R I P L E T T

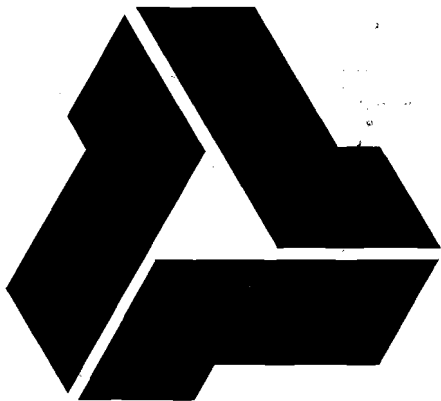

**TEST EQUIPMENT
INSTRUCTION
MANUAL**



TRIPLETT CORPORATION
Quality and Technology for Tomorrow

MODEL 630-PL & PLK

VOLT-OHM-MILLIAMMETER

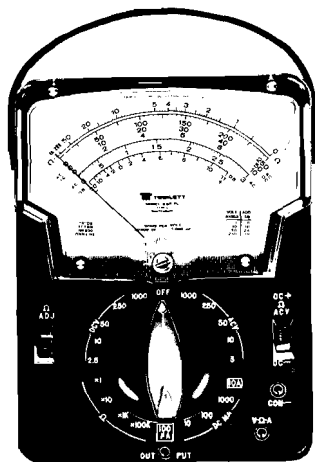

**TRIPLETT
CORPORATION**

One Triplet Drive
Bluffton, Ohio 45817

SAFETY RULES

Warning

This tester has been designed with your safety in mind. However, no design can completely protect against incorrect use. Electrical circuits can be dangerous and/or lethal when lack of caution or poor safety practices are used.

Read The Manual

Read this Instruction Manual carefully and completely.

Voltages and currents within the capability of this test equipment can be hazardous. Follow the instructions in this manual for every measurement. Read and understand the general instructions before attempting to use this tester. Do not exceed the limits of the tester.

Safety Check

Double check the switch setting and lead connections before making measurements. Are you following all of the instructions?

Disconnect the tester or turn off the power before changing switch positions.

Do not connect to circuits with voltage present when switch is in any ohms or current position.

When replacing fuses use only specified type fuses and insert in correct fuse holder.

Don't Touch

Don't touch exposed wiring, connections or other "live" parts of an electrical circuit. If in doubt, check the circuit first for voltage before touching it.

Turn off the power to a circuit before connecting test probes to it. Be sure there is no voltage present before you touch the circuit.

Do not use cracked or broken test leads.

High Voltage Is Dangerous

Always start with the power off. Be sure there is no voltage present before making connections to the circuit.

Don't touch the tester, its test leads, or any part of the circuit while it is on.

Before disconnecting the tester, turn the circuit off and wait for the meter to return to "zero."

Distribution Circuits Pack A Punch

In high energy circuits such as distribution transformers and bus bars, dangerous arcs of explosive nature can occur if the circuit is shorted. If the tester is connected across a high energy circuit when set to a low resistance range, a current range, or any other low impedance range, the circuit is virtually shorted.

Special equipment designed for use with these circuits is available. Contact a qualified person for assistance before attempting to make measurements on any high energy circuit.

Safety Is No Accident

TABLE OF CONTENTS

Safety Rules	2
Specifications	4
Introduction.....	6
Care Of Your VOM	7
Protection Features.....	8
General Instructions.....	10
Measuring DC Volts.....	12
Measuring AC Volts.....	13
Measuring DC Current	14
Measuring DC Resistance	15
Measuring Output Voltage.....	16
Measuring Decibels (dB).....	17
Maintenance	18
Accessories	19
Replaceable Parts 630-PL.....	24
Schematic 630-PL.....	26
Parts Location 630-PL	27
Replaceable Parts 630-PLK.....	28
Schematic 630-PLK.....	30
Parts Location 630-PLK.....	31
Limited Warranty.....	32

SPECIFICATIONS

DC Volts				
Ranges	0-250 Millivolt, 0 - 2.5, 10, 50, 250, 1000			
Accuracy	± 1 1/2% of Full Scale Reading (Calibrated at 77°F (25°C))			
Sensitivity	20,000 Ohms per Volt, 10,000 Ohms per Volt on 0-250 Millivolt			
Maximum Input Voltage	1000 Volts			
AC Volts				
Ranges	0 - 3, 10, 50, 250, 1000			
Accuracy	3% of Full Scale Reading (Calibrated at 77°F (25°C))			
Sensitivity	5000 Ohms per Volt			
Maximum Input Voltage	1000 Volts RMS			
DC Current				
Ranges	0-100 Microamperes at 250 mV 0 - 10, 100, 1000 Milliamperes at 250 mV 0-10 Amperes at approx. 1 Volt (at end of test leads)			
Ohms				
Ranges	0 - 1000, 10,000 . . . 0 - 1M, 100M (4.4 - 44, 4400 - 440,000 at Center Scale)			
Accuracy	± 1 1/2% of Full Scale Length			
	X1	X10	X1K	X100K
Maximum Voltage - Volts	1.6	1.6	1.6	34
Maximum Current - mA	364	36.4	.364	.0773
Maximum Power Transfer to Load - mW	150	75.0	.150	.655

Output Volts	0 - 3, 10, 50, 250 at 5000 Ohms per Volt
Decibels	-20 to + 11, 21, 35, 49 on 600 Ohm Line
Scale	4.5 Inches Long (max.) Mirror Scale
Batteries	One 1.5 volt and one 30 volt battery. Batteries are packed separately.
Test Leads	One red and one black lead supplied, each 48 inches long. Two insulator type alligator clips included.
Rubber Feet	Four rubber feet are supplied to fit into four holes in the rear of VOM case.
Size	3 11/32" x 5 1/2" x 7 1/2"
Weight	Approximately 4 pounds
Temperature Influence	The meter movement has a temperature coefficient of less than +0.1%/°C without any special compensation devices. Resistors have a temperature coefficient of less than ±150 PPM/°C. This allows a temperature influence of less than ±0.025%/°C on the resistance ranges and all DC voltage ranges except the 250 Millivolt range.

INTRODUCTION

Your VOM is a compact, rugged, portable volt-ohm-milliammeter. It has been designed to make fast, accurate measurements on all types of electrical and electronic equipment and is backed by a company which has been making quality instruments and test equipment for over half a century.

The indicating portion of the VOM is actuated by the latest concept in instrumentation, namely, a taut band suspension meter (shown below) having a sensitivity of 50 microampere full scale. This meter, by omitting conventional pivots, bearings and hairsprings provides the following advantages.

1. Increased repeatability by elimination of friction between pivots and bearings.

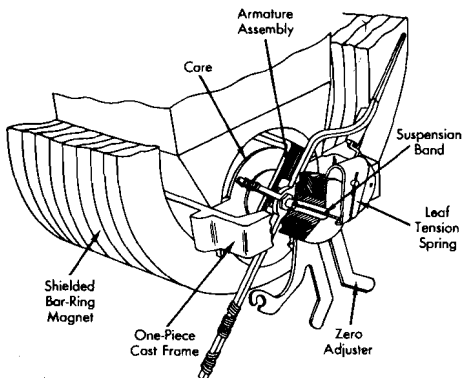

2. Greater ruggedness and durability as no moving parts are in contact and the elimination of the hairspring prevents snagging and tangling. The tension spring acts as a built-in shock absorber.
3. Temperature variations can not cause sticky operation of the pointer.

Reference to the illustration will assist in understanding the principle of operation. The moving coil floats in the magnet by virtue of the suspension bands which are held in tension by a spring. These bands, which are fabricated of a precious metal alloy, provide torque and carry the current to the moving coil. The moving coil assembly is held by a rigid one piece die cast frame in a large self-shielded "Bar Ring" magnet.

CARE OF YOUR VOM

- Although this instrument is portable and rugged it should be treated with care. Do not drop or handle it roughly.
- Avoid placing it on a bench where machine tools are used or severe vibration is encountered.
- When possible keep it in a place of moderate temperature. Avoid subjecting it to extreme temperatures and severe temperature changes.
- If the VOM has not been used for a long period of time, rotate the selector switch in both directions several times to wipe the switch contacts for good contact.
- Turn the selector switch to OFF when the VOM is to be carried. The meter is damped in the OFF position to prevent wild swinging of the pointer.

MODEL 630-PLK

PROTECTION FEATURES

Your VOM is equipped with an overload protection circuit to protect against overloads which normally would damage or destroy circuit components and/or the meter. The protection circuit uses a transistorized amplifier which controls a manually reset latching type relay. The amplifier senses the voltage across the meter terminals. When this voltage reaches four to six times the rated full scale meter voltage, the amplifier "fires" and energizes the relay. Smaller overloads not sufficient to make the amplifier "fire" will not cause damage to the instrument. The relay contacts, located in the VOM input circuit, latch open and remain open until the manual reset button (located to the right of the selector switch on the front panel) is depressed.

In the normal operating condition (reset button in), the transistorized protection amplifier draws negligible stand-by current (less than 1 microampere—the approximate shelf life drain on the 30 volt battery).

The overload protection feature is intended to guard against occasional human error, not to encourage careless instrument use. Particular care should be exercised to prevent the application of voltages exceeding 100 volts to the current and low ohms ranges as the low impedance of these circuits may cause momentary surges of current beyond the capacity of the overload relay contacts. The fuse in the input circuit provides added protection for the relay contacts; under some conditions the fuse may blow in addition to the overload relay contacts opening.

All ranges are provided with protection to prevent damage as follows:

1. The 1 and 10 ampere ranges are protected by 1 and 10 ampere fuses respectively.
2. The inherent high resistance of the 100K ohm, 1000 Volt AC and DC range circuits limits current to a level which will not damage the instrument.
3. All other ranges are protected by the transistorized overload protection circuit previously described.

As an added protection to the meter, a silicon diode network prevents damage to the meter pointer by by-passing instantaneous transient voltages that might bend the meter pointer before the relay contacts open.

PRECAUTIONS

The 30 volt ohmmeter battery must be installed and tested before the VOM is placed in service since this battery is used in the overload protection circuit. After installing the batteries, they should be tested as follows:

1. Turn the selector switch to the X100K position.
2. Short the test leads together.
3. Adjust the meter pointer to zero ohms with the ohms adjust control. If the pointer cannot be set at zero the 30 volt battery should be replaced at once. DO NOT operate the VOM if the 100K ohms range will not zero since the overload protector will not operate properly.

This procedure should be repeated periodically to insure proper operation of the overload protection circuits.

GENERAL INSTRUCTIONS

The following section should be read carefully; it contains instructions and precautions to be observed in making measurements with the VOM.

- Measurements are made with the test leads plugged into the COM - and V- Ω -A jacks, except when measuring output volts (dB). For these ranges the V- Ω -A test lead is plugged into the appropriate jack (one test lead is in the COM - jack for all measurements).
- The insulated alligator clips provided with the VOM fit over the end of the test probes. When measuring high voltages, the use of these alligator clips will allow measurement without handling the test probes. As a safety measure, always shut off power source before attempting to connect alligator clips.

Caution: If the VOM has been overloaded—disconnect the test probes from the power source before depressing the “reset” button.

- When the approximate value of the quantity being measured is not known, always start on the highest range. For greatest accuracy, choose the range which will allow readings to be taken in the upper (right hand) portion of the scale.
- Readings are taken on the scale having the appropriate significant figures (both 2.5 and 250 volts are read on the 0-250 scale) by multiplying or dividing by a factor of 10 or 100 as indicated by the range scale ratio (i.e.; on the 2.5 volt range divide the scale readings by 100).
- The polarity reversing switch reverses the polarity of the entire VOM at the input jacks. This allows fast switching in case of wrong polarity; and also provides a convenient polarity reversal for ohms ranges, a very useful tool in semiconductor checking. The V- Ω -A jack is positive when the polarity switch is in the DC+ - Ω -ACV position.
- Whenever possible, the test probes should be disconnected from the voltage source (or the source shut off) before the range switch or polarity switch positions are changed. This practice will result in an increased life and reliability for the VOM.

- The Meter Zero Adjust Screw is located on the lower center of the meter cover. It should be periodically adjusted so the meter pointer is on zero with no input into the VOM.
- Readings on the sensitive voltage, current and resistance ranges may sometimes be different than calculated values. Thermo-electric or electro-chemical reaction can sometimes generate voltage (or current) in a circuit due to elevated temperatures from soldering, contact of dissimilar metals, chemical fumes or moisture. Also, the fingers should never touch the metal parts of the test probes since body resistance can cause erroneous readings—particularly on the high ohmmeter ranges.
- Check the test leads periodically. Leads that are worn, have damaged insulation, damaged plugs, damaged probes or loose parts should be replaced.

CAUTION: Always observe the following rules and procedures when making measurements in high voltage circuits:

1. Turn off equipment or other source of voltage, before connecting test probes. Make sure no capacitors in the circuit being tested remain charged to a high voltage.
2. Install alligator clips on test probes. While holding the insulated section of the test probe, check circuit to see if any voltage (or current) is present. If no voltage is present, connect the alligator clips to the circuit to be measured.
3. Turn on equipment, or voltage source, and take required readings. **DO NOT** handle or touch the VOM, test leads or test probes with power source turned on.

Observing the above rules and precautions will result in continued accurate measurements with your VOM or increased safety to equipment and personnel.

MEASURING DC VOLTS

0-250 DC Millivolts:

1. Insert test leads in V- Ω -A and COM - jacks.
2. Place selector switch in 100 μ A position.
3. Connect the test probes across the voltage to be measured as shown in Fig. 1.
4. Read DC millivolts on black "AC-DC" scale.

0-2.5 thru 0-1000 DC Volts:

1. Insert test leads in V- Ω -A and COM - jacks.
2. Place selector switch in appropriate DCV position.
3. Connect the test probes across the voltage to be measured as shown in Fig. 1.
4. Read voltage on black "AC-DC" scale.

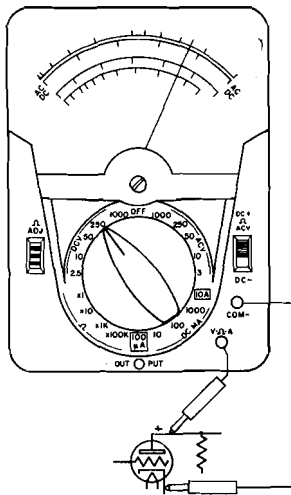

Fig. 1 Measuring DC Volts

MEASURING OUTPUT VOLTAGE

Output voltage is the AC part of a combined AC and DC voltage. Such a voltage is usually found in amplifier circuits, but it may also be found in other circuits. To measure output voltage, the DC part of the combined voltage must be removed or "blocked." This is done by inserting a capacitor in series with the AC voltage section of the VOM. The VOM has a .1 μ F 400 VDC capacitor between the OUTPUT and V- Ω -A jacks to do this.

0-3 Volts (Figure 5):

1. Insert test leads into the OUTPUT and COM - jacks.
2. Set the selector switch to 3 ACV position.
3. Connect test probes across the voltage to be measured.
4. Read voltage on the Red 0-3 "ACV" scale.

0-10 thru 0-250 Volts (Figure 5):

1. Insert test leads into the OUTPUT and COM - jacks.
2. Set selector switch to appropriate ACV range.
3. Connect test probes across the voltage to be measured.
4. Read voltage on "AC-DC" scale.

DO NOT USE THE OUTPUT range in circuits where the sum of the DC voltage and the peak AC voltage is greater than 400 volts.

The impedance of the capacitor is generally insignificant at audio frequencies. However, it may cause the meter to read low at low frequencies. Its effect should be considered in critical low frequency measurements.

WHEN THE VOLTAGE BEING MEASURED is AC with no DC present, the standard AC voltage measurement procedure should be used.

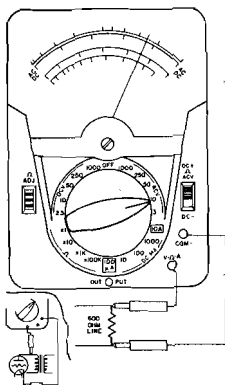

Fig. 5. Measuring Output

MEASURING DECIBELS (dB)

The decibel is a unit that expresses the ratio of power levels. It is mathematically derived to reduce multiplication and division to addition and subtraction, respectively, (e.g. — 10 dB represents multiplication by 10, 20 dB — 100, 30 dB — 1000). The decibel roughly approximates human hearing ratios. For this reason, it is commonly used in audio and telephone measurements.

Because the decibel represents a ratio, there is a reference level. The reference level for 0 dB is 1 milliwatt into a 600 ohm load (.775 ACV across 600 ohms). Measurements made across loads other than 600 ohms are relative measurements.

To measure decibels, connect the VOM the same as for measuring AC voltage (or OUTPUT voltage, if there is DC voltage present). But, read the dB scale instead of the voltage scales. A chart on the dial shows the dB values to be added to the reading for the different voltage ranges. (e.g. — When the selector switch is set to the 50 VAC position, add 24 dB to the indicated value.) As explained above, addition of dB represents multiplication of power (or voltage).

MAINTENANCE

Battery Replacement

Two batteries are used in the ohmmeter circuits.

A 1.5 volt battery, (size D NEDA 13F), is used in the X1, X10, and X1K ranges. If the pointer cannot be adjusted to zero when the selector switch is on one of these ranges and the test prods are touched together, the 1.5 volt battery should be replaced.

A 30 volt battery, NEDA 210, is used in the X100K range. The 30 volt battery should be replaced if the pointer cannot be adjusted to zero when the selector switch is on the X100K range and the test prods are touched together.

The 30 volt battery is also used in the overload protective circuit. This battery must be installed and in good condition or the overload protective circuit will not operate.

To replace the batteries, remove the four screws in the bottom of the case and lift the back up and off. Remove the old batteries and replace with new ones. Be careful to observe polarity as indicated on the battery compartment.

Fuse Replacement

Spare 1 amp and 10 amp fuses are supplied with this instrument and are stored in the bottom of the battery compartment. CAUTION: Use only the fuses supplied or identical fuses as listed in the parts list. The substitution of fuses of other types and values may not afford proper protection and may also disturb the accuracy of the meter.

Cleaning The Plastic Window

The plastic window has been treated at the factory to dissipate static charges that otherwise would attract the meter pointer and make it cling to the window.

If cleaning is required use cotton dipped in a solution of household detergent and water. After cleaning allow the solution to dry without rubbing or polishing.

Parts Replacement

Parts available for replacement are listed in the parts list. When replacing any parts, be careful to not disturb or damage any others. Do not overheat resistors or diodes, but be sure to make a good solder connection.

In some cases, it is wise to leave part of the lead from the old component and solder the new component to the old lead to prevent damage to surrounding components.

If there is evidence of smoke or an electrical arc inside the VOM, return the VOM to the factory or an authorized service center. There is a chance of hidden damage that could cause another failure in the VOM.

Calibration

With normal use, readjustment of this VOM should not be necessary. Replacement parts are designed to be installed without any need for recalibration of the VOM. An occasional check of the VOM against a known reference voltage or another VOM is good practice. If there is a question about the accuracy of the VOM, it should be returned to the factory or an authorized service center for a calibration check.

ACCESSORIES

The usefulness and range of your VOM can be extended by the use of the following listed accessories.

High Voltage Measurement

Accessory probes are available for measuring high voltages such as found in television receivers and other equipment. To use these probes, plug the probe into the V- Ω -A jack, connect the black ground lead into the COM - jack, and set the selector switch to the position indicated below.

Use extreme caution in measuring high voltages—observe all the rules and precautions listed in the “General Instructions” regarding high voltage measurements.

Probe Part No. Kilovolt	Range	Set Selector Switch To:	Read on Range:	Multiply By:
79-449	0-5KV DC	2.5V DC	0-50V DC	100
79-450	0-5KV AC	3V AC	0-50V AC	100

AC Current Measuring Adapter

AC line loads can be checked easily, without breaking the conductors or insulation of the circuit under test, when the Model 10 CLAMP-ON AMMETER ADAPTER (Cat. No. 60-211) is used. The Adapter is connected with a No. 611 LEAD ASSEMBLY (Part No. 79-415). The lever on the side of the Model 10 Adapter, is pressed to open the split yoke of the adapter so it can be placed over and closed around the lead or bus bar carrying the current being measured. Readings up to 300 AC amperes can be made.

MODEL 10 CLAMP-ON ADAPTER,

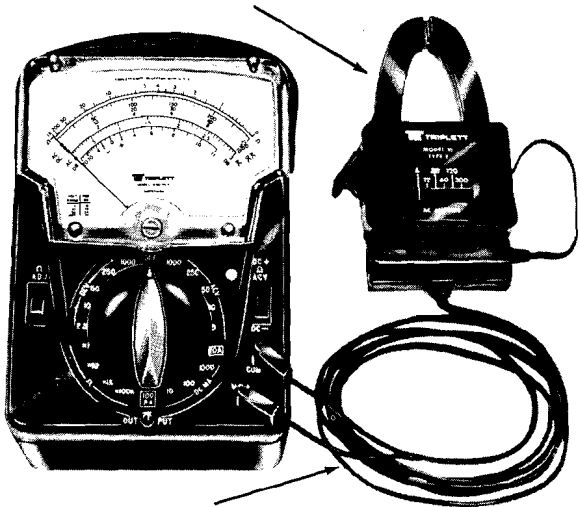

NO. 611 LEAD ASSEMBLY

Fig. 7. Model 10 Clamp-On Adapter

THE MODEL 101 LINE SEPARATOR (Cat. No. 60-218) is used to divide a circuit using two-conductor cable so one conductor can be encircled by the adapter yoke. The Model 101 is plugged into the AC outlet and the AC cord of the equipment to be measured is plugged into the appropriate socket on the Model 101. The split yoke of the Model 10 Adapter is clipped through the loop in the Model 101 to make the current measurement. Use of the "Divide by 10" and "Divide by 20" sockets on the Model 101 Line Separator makes a convenient and fast method of measuring extremely low AC current.

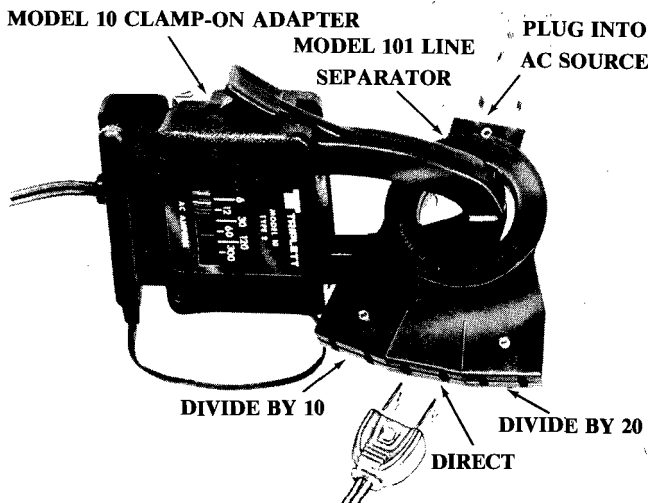
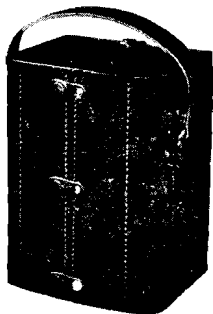

Fig. 8. Model 101 Line Separator

Carrying Cases



Model 639-N

639-N black manmade leather carrying case. For use with 630 series testers. Stand included at no extra cost. Leather strap handle. Model 639 quality carrying case has adequate space for Triplet 630 series tester, instructions, and accessories. Black manmade leather, provided with strong quality strap handle.

Model 639-P is a quality carrying case padded with 3/8" sponge rubber which gives the instrument maximum protection. Has adequate space for any 630 series tester, instructions, and leads. Black manmade leather with strap handle.

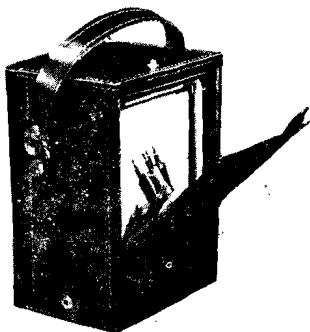

Rear view shows large accessory compartment permitting free access to tester stand, leads and instructions.

Model 639/639-P

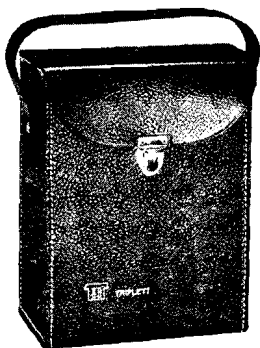



Carrying
Case

Model 639-OS

Case 639-OS

Black quality case, has built-in stand on back. Flaps open to permit use of tester in case. Compartment for accessories. For use with 630 series testers. Felt lined, leather strap handle.

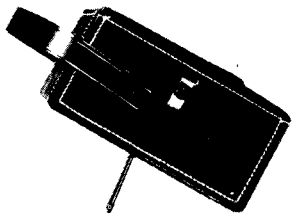

MODEL 630-PL TYPE 6 REPLACEABLE PARTS

Ref. No.	Description	Part Number
B1	Battery 30V (NEDA 210)	37-19
B2	Battery 1.5V (NEDA 13F)	2426-1
C1	Capacitor .1 μ F 400V	43-69
F1	Fuse 10 Amp 250V	3207-21
F2	Fuse 1 1/4 Amp 250V	3207-67
M1	Meter VOM Front	52-8587
R1	Resistor 3.75 Meg	15-2858
R2	Resistor 1 Meg	15K-1004UC5
R3	Resistor 200k	15K-2003UC5
R4	Resistor 35k	15K-3502UC5
R5	Resistor 5000 Ω	15K-5001TC5
R6	Resistor 5000 Ω	15K-5001TC5
R7	Resistor .25 Ω	15-5376
R8	Resistor 2.5 Ω	15-2869
R9	Resistor 25.12 Ω	15-2850
R10	Resistor 5000 Ω	15K-5001UC5
R11	Resistor 423k	15K-4233UC5
R12	Resistor 13.6k	15K-1362TC5
R13	Resistor 4690 Ω	15K-4691UC5
R14	Resistor 37.2 Ω	15-4115
R15	Resistor 3.7 Ω	15-3223
R16	Resistor 732 Ω	15K-7320TC5
R17	Resistor 6.5 Ω	15-4114
R18	Resistor 45k	15K-4502UC5
R19	Resistor 150k	15K-1503UC5
R20	Resistor 800k	15K-8003UC5
R21	Resistor 4 Meg	15-2866
R22	Resistor 7.5 Meg	15-2867
R23	Resistor 7.5 Meg	15-2867
R24, R25, R26	Not Used	24

Ref. No.	Description	Part Number
R27	Ω ADJ Control 20k	16-31
R28	Shunt Assembly 10 AMP	90-1036
R29, R30	Not used	
R31	Resistor 5100 Ω	15R-512JC
SW1	Switch	22-319
	Switch, with Resistors	22-585
SW2	Switch, Slide	22-152
CRA1	Rectifier Assem.	2250-30
CR1A, CR1B	Diode Assembly Meter Protect	127-114
	Knob Red, with Spring	34-62
	Case with Handle	10-784
	Test Leads	79-127

Repair or Service

For repair of the VOM, return it to the factory or an authorized service center. To help in repairing the VOM, give a detailed description of the problem and any other data that might be helpful such as what kind of circuit was being measured when the problem was discovered.

If the VOM is damaged by an overload and there is evidence of smoke or an electrical arc inside, return it to the factory or an authorized service center for inspection and repair. There could be some hidden damage that would cause a future failure of the VOM.

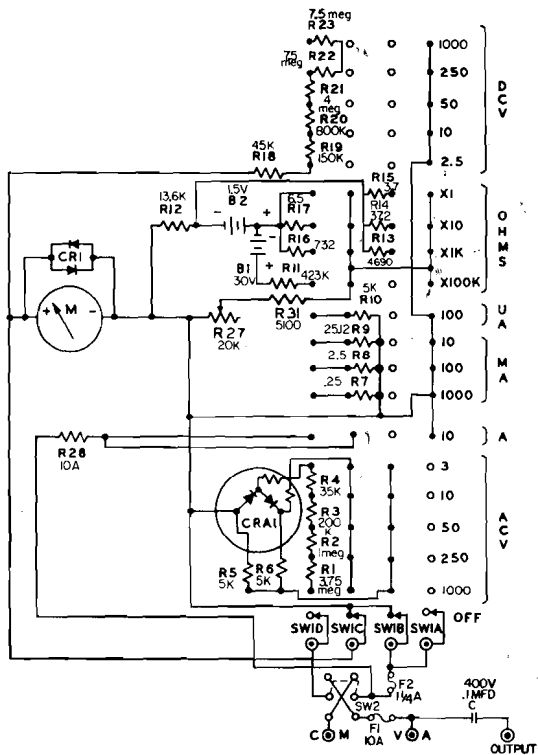

Schematic 630-PL

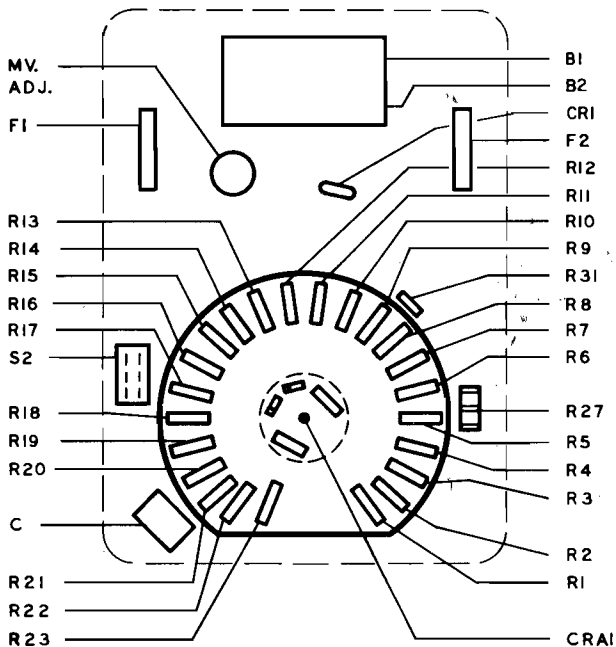

Parts Location 630-PL

**MODEL 630-PLK TYPE 9
REPLACEABLE PARTS**

Ref. No.	Description	Part Number
B1	Battery 30V (NEDA 210)	37-19
B2	Battery 1.5V (NEDA 13F)	2426-1
C1	Capacitor .1 μ F 400V	43-69
C2	Capacitor 10 μ F 50V	43-256
F1	Fuse 10 Amp 250V	3207-21
F2	Fuse 1 Amp 125V	3207-58
M1	Meter VOM Front	52-8987
R1	Resistor 3.75 Meg	15-2858
R2	Resistor 1 Meg	15K-1004UC5
R3	Resistor 200K	15K-2003UC5
R4	Resistor 35k	15K-3502UC5
R5	Resistor 5000 Ω	15K-5001TC5
R6	Resistor 5000 Ω	15K-5001TC5
R7	Resistor .25 Ω	15-5376
R8	Resistor 2.5 Ω	15-2869
R9	Resistor 25.12 Ω	15-5897
R10	Resistor 5000 Ω	15K-5001UC5
R11	Resistor 8600 Ω	15K-8601TC5
R12	Resistor 423k	15K-4233UC5
R13	Resistor 732 Ω	15K-7320TC5
R14	Resistor 6.5 Ω	15-4114
R15	Resistor .15 Ω	15-4261
R16	Resistor 37.2 Ω	15-4115
R17	Resistor 4690 Ω	15K-4691TC5
R18	Resistor 45k	15K-4502UC5
R19	Resistor 150k	15K-1503UC5
R20	Resistor 800k	15K-8003UC5
R21	Resistor 4 Meg	15-2866
R22	Resistor 7.5 Meg	15-2867
R23	Resistor 7.5 Meg	15-2867
R24, R25, R26	Not used	

Ref. No.	Description	Part Number
R27	Ω ADJ Control 20k	16-31
R28	Shunt Assembly 10AMP	90-1037
R29, R30	Not used	
R31	Resistor 5100 Ω	15R-512JC
R32	Resistor 3.66 Ω	15-5898
SW1	Switch	22-466
	Switch, with Resistors	22-584
SW2	Switch, Slide	22-152
CRA1	Rectifier Assem.	2250-30
CR1	Diode Assembly Meter Protection	11670
CRA2	Overload Protection Circuit Board	87-1054
	Knob Red, with Spring	34-62
	Case with Handle	10-784
	Test Leads	79-127
	Pushbutton	62-7
	Spring	42-232

Repair or Service

For repair of the VOM, return it to the factory or an authorized service center. To help in repairing the VOM, give a detailed description of the problem and any other data that might be helpful such as what kind of circuit was being measured when the problem was discovered.

If the VOM is damaged by an overload and there is evidence of smoke or an electrical arc inside, return it to the factory or an authorized service center for inspection and repair. There could be some hidden damage that would cause a future failure of the VOM.

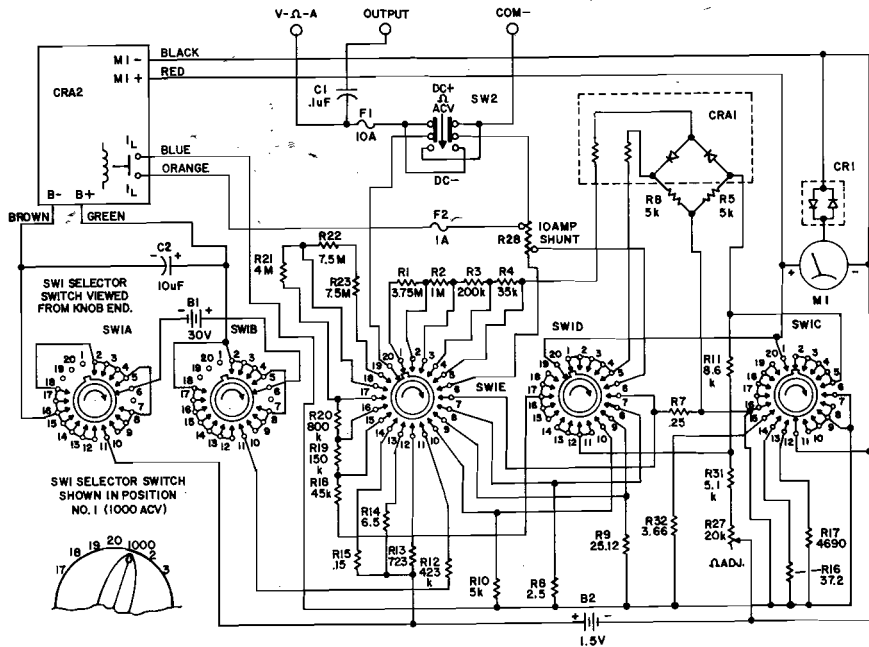

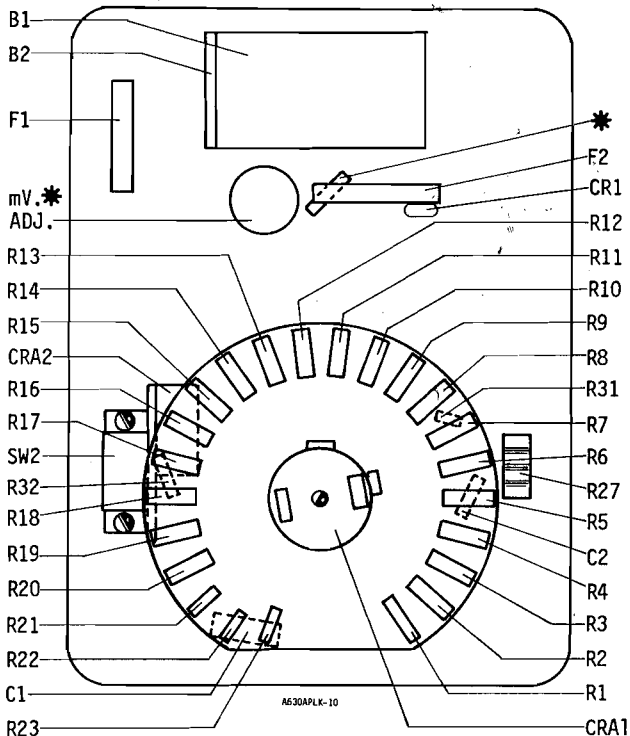

* PART OF METER CIRCUIT

LIMITED WARRANTY

The Triplett Corporation warrants instruments and test equipment manufactured by it to be free from defective material or factory workmanship and agrees to repair or replace such products which, under normal use and service, disclose the defect to be the fault of our manufacturing, with no charge for parts and service. If we are unable to repair or replace the product, we will make a refund of the purchase price. Consult the Instruction Manual for instructions regarding the proper use and servicing of instruments and test equipment. Our obligation under this warranty is limited to repairing, replacing or making refund on any instrument or test equipment which proves to be defective within three years (one year guaranteed calibration) from the date of original purchase.

This warranty does not apply to any of our products which have been repaired or altered by unauthorized persons in any way so as, in our sole judgment, to injure their stability or reliability, or which have been subject to misuse, abuse, misapplication, negligence or accident or which have had the serial numbers altered, defaced, or removed. Accessories, including batteries and fuses, not of our manufacture used with this product are not covered by this warranty.

To register a claim under the provisions of this warranty, return the instrument or test equipment to Triplett Corporation, Bluffton, Ohio 45817, transportation prepaid. Upon our inspection of the product, we will advise you as to the disposition of your claim.

ALL WARRANTIES IMPLIED BY LAW ARE HEREBY LIMITED TO A PERIOD OF THREE YEARS, AND THE PROVISIONS OF THE WARRANTY ARE EXPRESSLY IN LIEU OF ANY OTHER WARRANTIES EXPRESSED OR IMPLIED.

The purchaser agrees to assume all liability for any damages and bodily injury which may result from the use or misuse of the product by the purchaser, his employees, or others, and the remedies provided for in this warranty are expressly in lieu of any other liability Triplett Corporation may have, including incidental or consequential damages.

Some states (USA only) do not allow the exclusion or limitation of incidental or consequential damages, so the above limitation or exclusion may not apply to you. No representative of Triplett Corporation or any other person is authorized to extend the liability of Triplett Corporation in connection with the sale of its products beyond the terms hereof.

Triplett Corporation reserves the right to discontinue models at any time, or change specifications, price or design, without notice and without incurring any obligation.

This warranty gives you specific legal rights, and you may have other rights which vary from state to state.

TRIPLETT CORPORATION
Bluffton, Ohio 45817

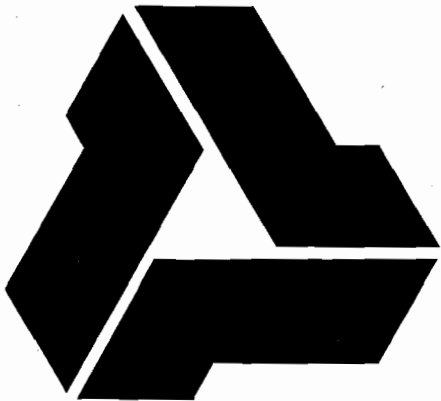

TRIPLETT CORPORATION

Quality and Technology for Tomorrow

ONE TRIPLETT DRIVE, BLUFFTON, OH 45817

(419) 358-5015 1-800-874-7538

FAX (419) 358-7956